



深圳职业技术学院

建筑工程学院

School of Construction Engineering

插花与花艺设计

— 西方基本花型

谢利娟

深圳职业技术学院风景园林设计专业

深圳市南山区西丽湖，518055

电话：13510800260

E-mail: 850826838@qq.com



插花与花艺设计西方基本花型



09

西方基本花型

——平行设计





插花与花艺设计西方基本花型—平行设计





插花与花艺设计西方基本花型—平行设计





插花与花艺设计西方基本花型—平行设计

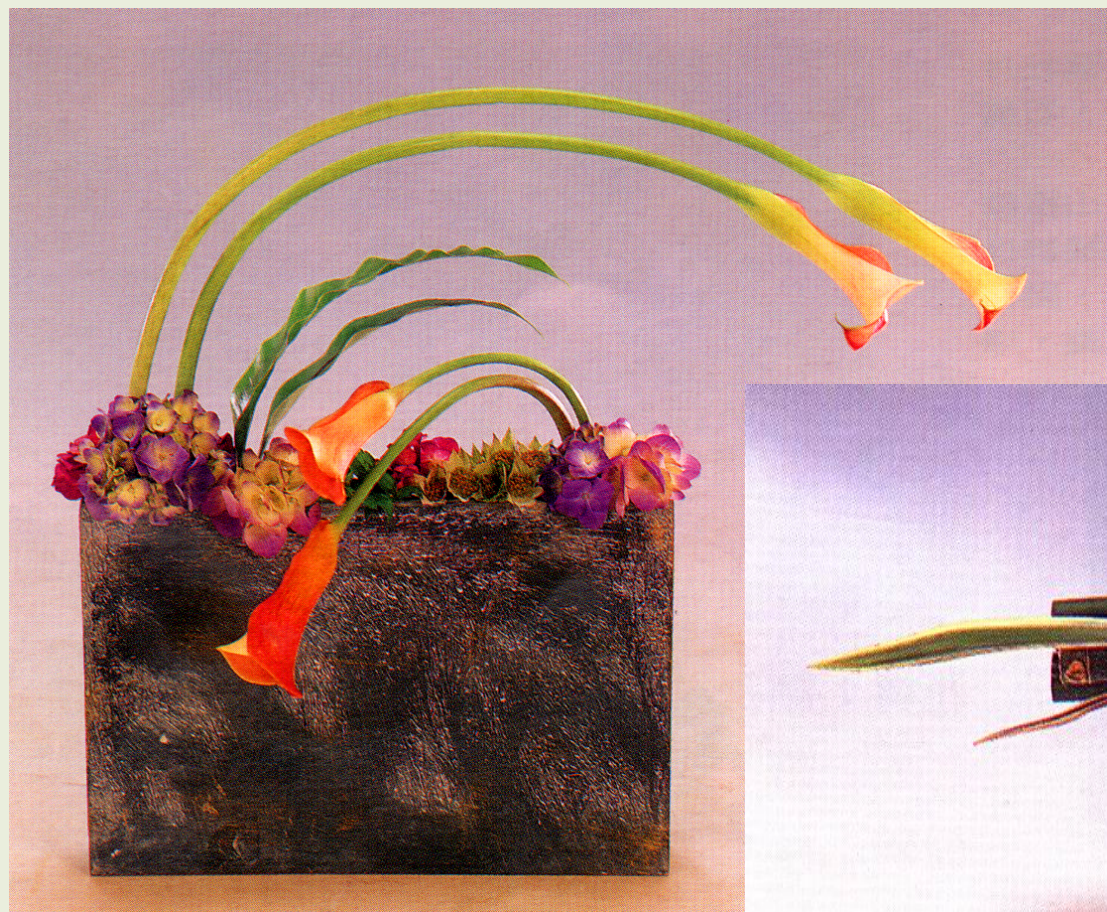



插花与花艺设计西方基本花型—平行设计

何为平行设计？

(Parallel Arrangement)

同组花材之间

保持平行的

一种花型。





插花与花艺设计西方基本花型—平行设计

1. 平行设计的设计重点

(1) 花器的选择

一般，竖向的平行设计作品，宜选择**长条型**花器

横向的水平设计作品（也可视为现代水平型），则无严格要求

为什么？

(2) 花泥的装法：一般，平行设计的花泥**不宜高过**花器口

为什么？



插花与花艺设计西方基本花型—平行设计

1. 平行设计的设计重点

(3) 花材的选配

架构花：宜选择茎杆笔直或曲线优美的花材，突出平行设计的线条

一般，架构花应有两组以上

底部花：宜块状、点状或面状花叶

一般，底部花叶宜丰富，也有很简洁的设计手法

色彩：同一色、近似色、对比色都可以

只要组合恰当，都能有惊人效果



插花与花艺设计西方基本花型—平行设计

1. 平行设计的设计重点

(4) 造型设计要点

- A** 组内花材之间，由底部至顶端都必须保持平行
- B** 一般建议选用几组花材，即每一组群最好是不同的花或叶
- C** 每一组群间必须留有空间
- D** 组与组之间可以平行或交叉
- E** 注意每一组群间的高低比例及色彩的搭配
- F** 注意铺底



插花与花艺设计西方基本花型—平行设计

这是平行设计吗？为什么？





插花与花艺设计西方基本花型—平行设计





插花与花艺设计西方基本花型—平行设计

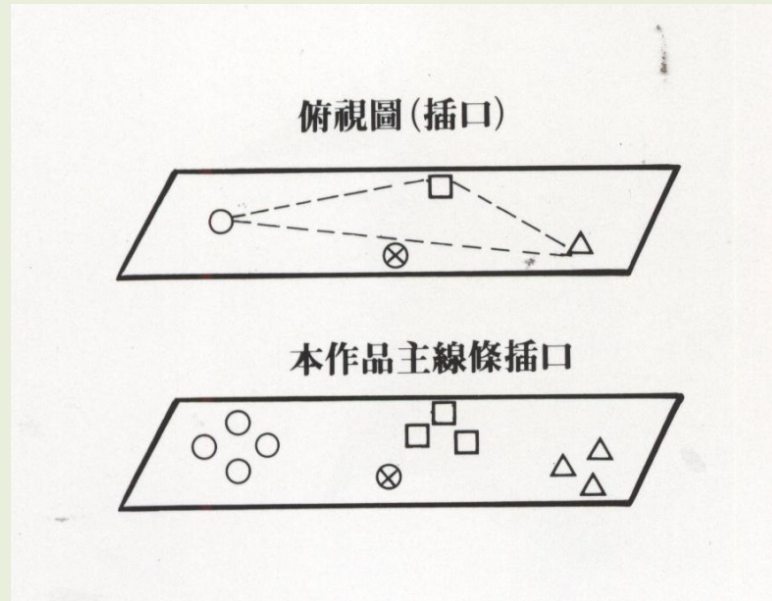
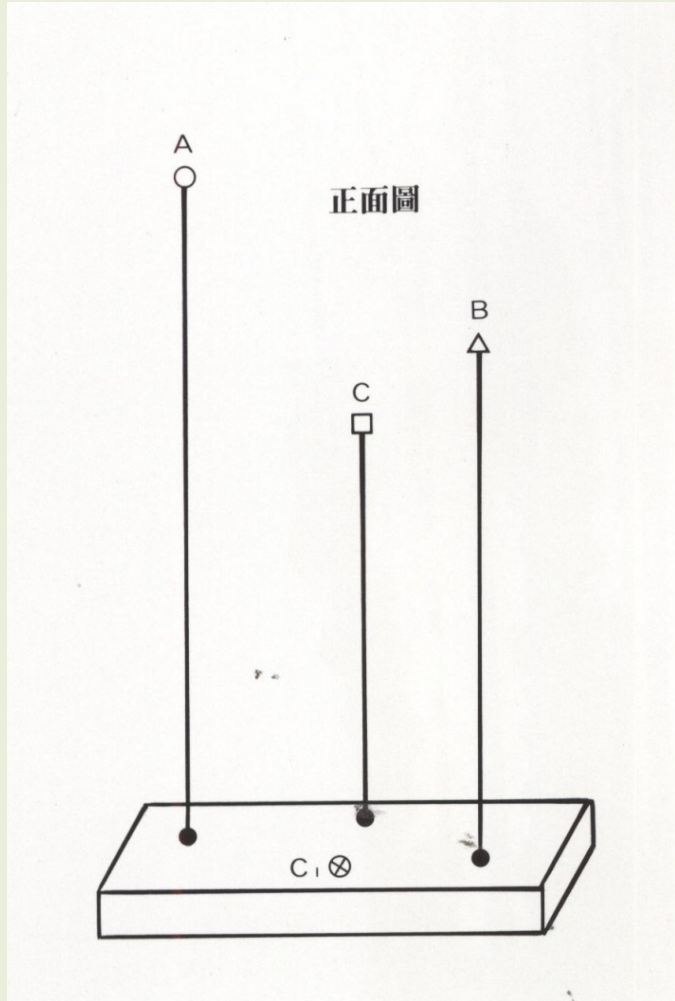



插花与花艺设计西方基本花型—平行设计

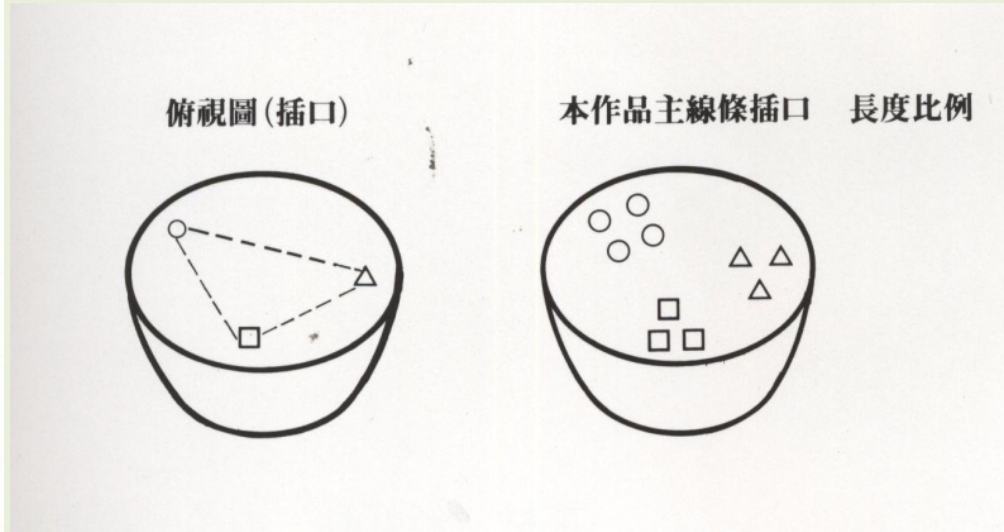
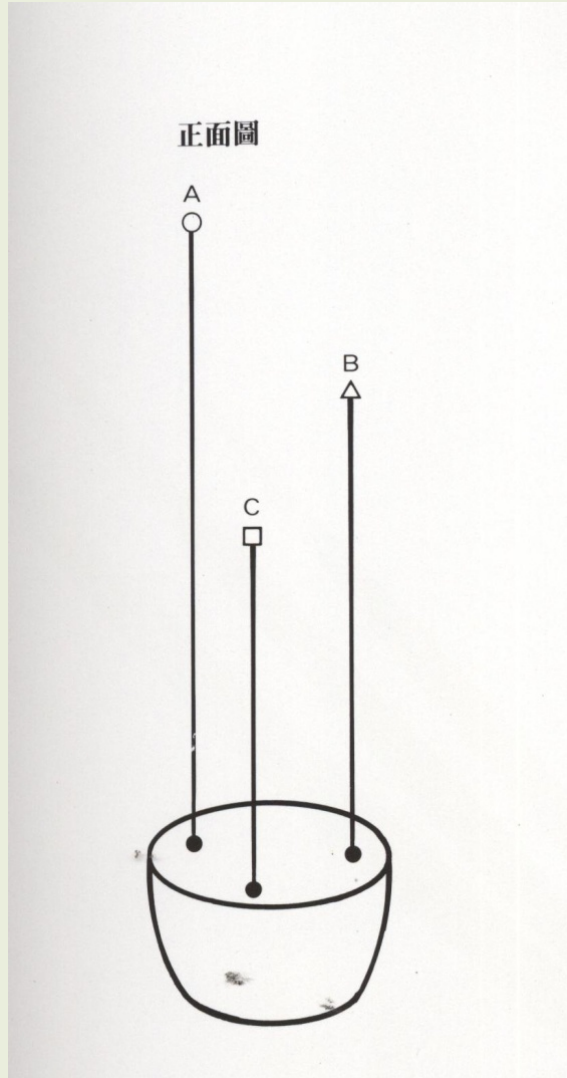



插花与花艺设计西方基本花型—平行设计

正面圖

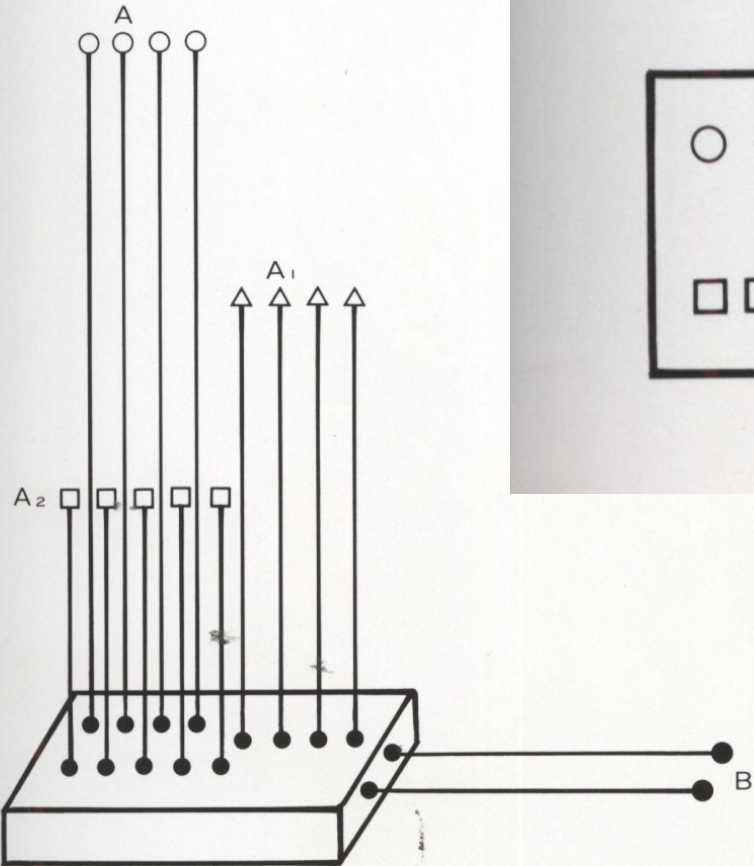

俯視圖(插口)

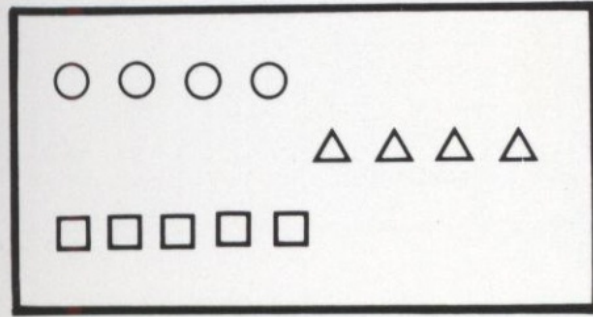



深圳职业技术学院

建筑工程学院

School of Construction Engineering

谢 谢

